



## JEE Main 25 Jan 2023(Second Shift)

**Total Time: 180**

**Total Marks: 300.0**

### Physics

**Q.No.1:** Every planet revolves around the sun in an elliptical orbit:

A. The force acting on a planet is inversely proportional to square of distance from sun.

B. Force acting on planet is inversely proportional to product of the masses of the planet and the sun.

C. The Centripetal force acting on the planet is directed away from the sun.

D. The square of time period of revolution of planet around sun is directly proportional to cube of semi-major axis of elliptical orbit.

Choose the correct answer from the options given below:

- A. C and D only
- B. B and C only
- C. A and C only
- D. A and D only

**Marks:[4.00]**

**Q.No.2:** Match List I with List II

| List I |                    | List II |   |
|--------|--------------------|---------|---|
| A.     | Isothermal Process | I.      | Work done by the gas decreases internal energy                                  |
| B.     | Adiabatic Process  | II.     | No change in internal energy  |
| C.     | Isochoric Process  | III.    | The heat absorbed goes partly to increase internal energy and partly to do work |
| D.     | Isobaric Process   | IV.     | No work is done on or by the gas  |

Choose the correct answer from the options given below:

- A. A-I, B-II, C-III, D-IV
- B. A-I, B-II, C-IV, D-III
- C. A-II, B-I, C-IV, D-III
- D. A-II, B-I, C-III, D-IV

Marks:[4.00]

**Q.No.3:** A point charge of  $10 \mu\text{C}$  is placed at the origin. At what location on the X-axis should a point charge of  $40 \mu\text{C}$  be placed so that the net electric field is zero at  $x = 2 \text{ cm}$  on the X-axis?

- A.  $x = 8 \text{ cm}$
- B.  $x = 6 \text{ cm}$
- C.  $x = -4 \text{ cm}$
- D.  $x = 4 \text{ cm}$

Marks:[4.00]

**Q.No.4:** The graph between two temperature scales P and Q is shown in the figure. Between upper fixed point and lower fixed point there are 150 equal divisions of scale P and 100 divisions on scale Q. The relationship for conversion between the two scales is given by:

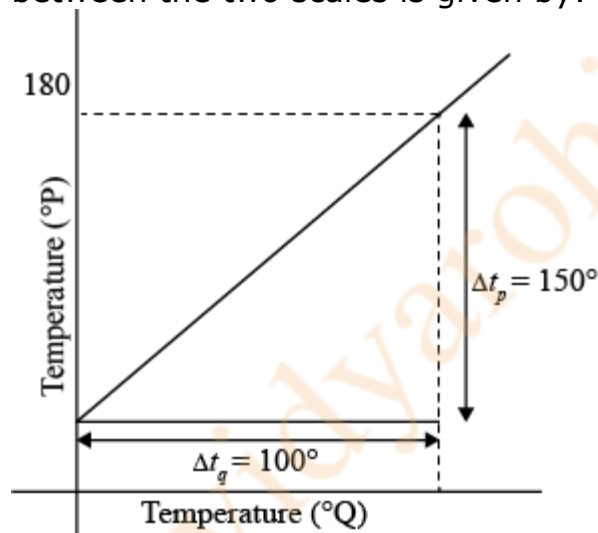

- A.  $\frac{t_P}{180} = \frac{t_Q - 40}{100}$
- B.  $\frac{t_Q}{100} = \frac{t_P - 30}{150}$
- C.  $\frac{t_P}{100} = \frac{t_Q - 180}{150}$
- D.  $\frac{t_P}{150} = \frac{t_Q - 180}{150}$

Marks:[4.00]

**Q.No.5:** Given below are two statements:

**Statement I:** Stopping potential in photoelectric effect does not depend on the

power of the light source.

**Statement II:** For a given metal, the maximum kinetic energy of the photoelectron depends on the wavelength of the incident light. In the light of above statements, choose the most appropriate answer from the options given below.

- A. Both Statement I and statement II are correct
- B. Statement I is correct but statement II is incorrect
- C. Both Statement I and Statement II are incorrect
- D. Statement I is incorrect but statement II is correct

**Marks:[4.00]**

**Q.No.6:** The light rays from an object have been reflected towards an observer from a standard flat mirror, the image observed by the observer are:-

- A. Real
- B. Erect
- C. Smaller in size than object
- D. Laterally inverted

Choose the most appropriate answer from the options given below:

- A. B and D Only
- B. A and D Only
- C. A, C and D Only
- D. B and C Only

**Marks:[4.00]**

**Q.No.7:** Two objects are projected with same velocity ' $u$ ' however at different angles  $\alpha$  and  $\beta$  with the horizontal. If  $\alpha + \beta = 90^\circ$ , the ratio of horizontal range of the first object to the 2nd object will be:

- A. 1 : 2
- B. 4 : 1
- C. 2 : 1
- D. 1 : 1

**Marks:[4.00]**

**Q.No.8:** Match List I with List II

| List I |                         | List II |   |
|--------|-------------------------|---------|---|
| A.     | Troposphere             | I.      | Approximate 65 - 75 km over Earth's surface |
| B.     | E-Part of Stratosphere  | II.     | Approximate 300 km over Earth's surface     |
| C.     | F2-Part of Thermosphere | III.    | Approximate 10 km over Earth's surface      |
| D.     | D-Part of Stratosphere  | IV.     | Approximate 100 km over Earth's surface     |

Choose the correct answer from the options given below:

- A. A-III, B-II, C-I, D-IV
- B. A-I, B-II, C-IV, D-III
- C. A-I, B-IV, C-III, D-II
- D. A-III, B-IV, C-II, D-I

**Marks:[4.00]**

**Q.No.9:** The energy levels of an atom is shown in figure.

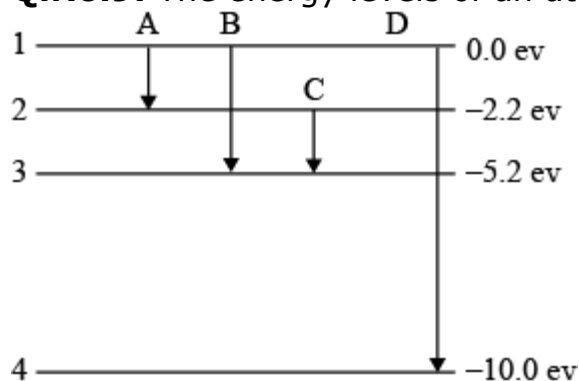

Which one of these transitions will result in the emission of a photon of wavelength 124.1 nm? Given ( $h = 6.62 \times 10^{-34}$  Js)

- A. D
- B. B
- C. C
- D. A

**Marks:[4.00]**

**Q.No.10:** For a moving coil galvanometer, the deflection in the coil is 0.05 rad when a current of 10 mA is passed through it. If the torsional constant of suspension wire is  $4.0 \times 10^{-5}$  N m rad<sup>-1</sup>, the magnetic field is 0.01 T and the number of turns in the coil is 200, the area of each turn (in cm<sup>2</sup>) is:

- A. 1.0
- B. 0.5
- C. 2.0
- D. 1.5

**Marks:[4.00]**

**Q.No.11:** A particle executes simple harmonic motion between  $x = -A$  and  $x = +A$ . If time taken by particle to go from  $x = 0$  to  $\frac{A}{2}$  is 2 s; then time taken by particle in going from  $x = \frac{A}{2}$  to  $A$  is

- A. 3 s
- B. 2 s

C. 1.5 s

D. 4 s

Marks:[4.00]

**Q.No.12:** A wire of length 1 m moving with velocity 8 m/s at right angles to a magnetic field of 2 T. The magnitude of induced emf, between the ends of wire will be\_\_\_\_\_

A. 20 V

B. 16 V

C. 8 V

D. 12 V

Marks:[4.00]

**Q.No.13:** The distance travelled by a particle is related to time  $t$  as  $x = 4t^2$  . The velocity of the particle at  $t = 5$  s is:

A.  $8 \text{ ms}^{-1}$

B.  $20 \text{ ms}^{-1}$

C.  $40 \text{ ms}^{-1}$

D.  $25 \text{ ms}^{-1}$

Marks:[4.00]

**Q.No.14:** A body of mass is taken from earth surface to the height  $h$  equal to twice the radius of earth ( $R_e$ ), the increase in potential energy will be:

( $g$  = acceleration due to gravity on the surface of Earth)

A.  $\frac{1}{3}mgR_e$

B.  $3mgR_e$

C.  $\frac{2}{3}mgR_e$

D.  $\frac{1}{2}mgR_e$

Marks:[4.00]

**Q.No.15:** Match List I with List II

| List I |                                      | List II |                   |
|--------|--------------------------------------|---------|-------------------|
| A.     | Young's Modulus ( $Y$ )              | I.      | $[ML^{-1}T^{-1}]$ |
| B.     | Co-efficient of Viscosity ( $\eta$ ) | II.     | $[ML^2T^{-1}]$    |
| C.     | Planck's Constant ( $h$ )            | III.    | $[ML^{-1}T^{-2}]$ |

|    |                                      |     |                |
|----|--------------------------------------|-----|----------------|
| D. | Co-efficient of Viscosity ( $\phi$ ) | IV. | $[ML^2T^{-2}]$ |
|----|--------------------------------------|-----|----------------|

Choose the correct answer from the options given below:

- A. A-I, B-II, C-III, D-IV
- B. A-III, B-I, C-II, D-IV
- C. A-II, B-III, C-IV, D-I
- D. A-I, B-III, C-IV, D-II

**Marks:[4.00]**

**Q.No.16:** Match List I with List II

| List I |                               | List II |  |
|--------|-------------------------------|---------|--|
| A.     | Gauss's Law in Electrostatics | I.      | $\oint \vec{E} \cdot d\vec{l} = -\frac{d\phi_B}{dt}$                             |
| B.     | Faraday's Law                 | II.     | $\oint \vec{B} \cdot d\vec{A} = 0$   |
| C.     | Gauss's Law in Magnetism      | III.    | $\oint \vec{B} \cdot d\vec{l} = \mu_0 i_c + \mu_0 \epsilon_0 \frac{d\phi_E}{dt}$ |
| D.     | Ampere-Maxwell Law            | IV.     | $\oint \vec{E} \cdot d\vec{s} = \frac{q}{\epsilon_0}$                            |

Choose the correct answer from the options given below:

- A. A-II, B-III, C-IV, D-I
- B. A-III, B-IV, C-I, D-II
- C. A-IV, B-I, C-II, D-III
- D. A-I, B-II, C-III, D-IV

**Marks:[4.00]**

**Q.No.17:** According to law of equipartition of energy the molar specific heat of a diatomic gas at constant volume where the molecule has one additional vibrational mode is

- A.  $\frac{3}{2}R$
- B.  $\frac{7}{2}R$
- C.  $\frac{9}{2}R$
- D.  $\frac{5}{2}R$

**Marks:[4.00]**

**Q.No.18:** Consider a block kept on an inclined plane (inclined at  $45^\circ$ ) as shown in the figure. If the force required to just push it up the incline is 2 times the force required to just prevent it from sliding down, the coefficient of friction between the block and inclined plane ( $\mu$ ) is equal to

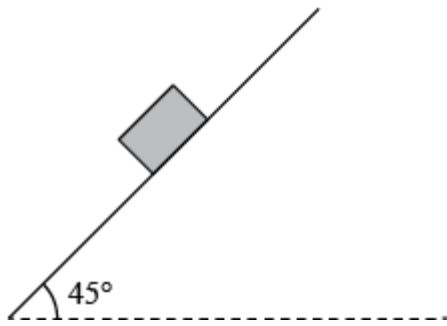

- A. 0.60
- B. 0.25
- C. 0.50
- D. 0.33

Marks:[4.00]

**Q.No.19: Statement I:** When a Si sample is doped with Boron, it becomes P type and when doped by Arsenic it becomes N-type semiconductor such that P-type has excess holes and N-type has excess electrons.

**Statement II:** When such P-type and N-type semi-conductors, are fused to make a junction, a current will automatically flow which can be detected with an externally connected ammeter.

In the light of above statements, choose the **most appropriate** answer from the options given below.

- A. Both statement I and statement II are correct
- B. Statement I is correct but statement II is incorrect
- C. Both statement I and statement II are incorrect
- D. Statement I is incorrect but statement II is correct

Marks:[4.00]

**Q.No.20:** The resistance of a wire is  $5 \Omega$ . It's new resistance in ohm if stretched to 5 times of its's original length will be

- A. 25
- B. 5
- C. 125
- D. 625

Marks:[4.00]

**Q.No.21:** Two long parallel wires carrying currents 8 A and 15 A in opposite directions are placed at a distance of 7 cm from each other. A point P is at equidistant from both the wires such that the lines joining the point P to the wires are perpendicular to each other. The magnitude of magnetic field at P is

\_\_\_\_\_  $\times 10^{-6}$  T.  
(Given :  $\sqrt{2} = 1.4$  )

**Marks:[4.00]**

**Q.No.22:** If a solid sphere of mass 5 kg and a disc of mass 4 kg have the same radius. Then the ratio of moment of inertia of the disc about a tangent in its plane to the moment of inertia of the sphere about its tangent will be  $\frac{x}{7}$ . . Then the value of x is \_\_\_\_\_

**Marks:[4.00]**

**Q.No.23:** An object is placed on the principal axis of convex lens of focal length 10 cm as shown. A plane mirror is placed on the other side of lens at a distance of 20 cm. The image produced by the plane mirror is 5 cm inside the mirror. The distance of the object from the lens is \_\_\_\_\_ cm

**Marks:[4.00]**

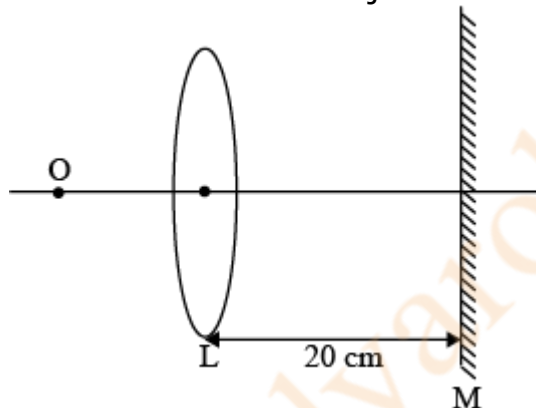

**Q.No.24:** Two cells are connected between points A and B as shown. Cell 1 has emf of 12 V and internal resistance of  $3 \Omega$ . Cell 2 has emf of 6 V and internal resistance of  $6 \Omega$ . An external resistor R of  $4 \Omega$  is connected across A and B. The current flowing through R will be \_\_\_\_\_ A.

**Marks:[4.00]**

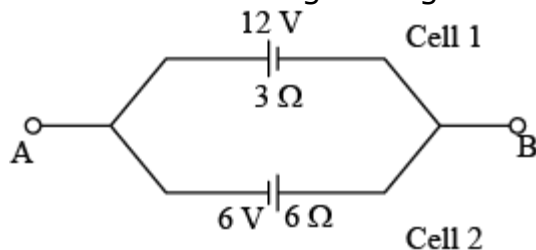



**Q.No.25:** A capacitor has capacitance  $5 \mu\text{F}$  when its parallel plates are separated by air medium of thickness  $d$ . A slab of material of dielectric constant 1.5 having area equal to that of plates but thickness  $\frac{d}{2}$  is inserted between the plates. Capacitance of the capacitor in the presence of slab will be \_\_\_\_\_  $\mu\text{F}$  **Marks:[4.00]**

**Q.No.26:** A train blowing a whistle of frequency 320 Hz approaches an observer standing on the platform at a speed of 66 m/s. The frequency observed by the observer will be (given speed of sound =  $330 \text{ ms}^{-1}$ ) Hz. **Marks:[4.00]**

**Q.No.27:** A nucleus disintegrates into two smaller parts, which have their velocities in the ratio 3 : 2. The ratio of their nuclear sizes will be  $\left(\frac{x}{3}\right)^{\frac{1}{3}}$ . The value of 'x' is **Marks:[4.00]**

**Q.No.28:** A body of mass 1 kg collides head on elastically with a stationary body of mass 3 kg. After collision, the smaller body reverses its direction of motion and moves with a speed of 2 m/s. The initial speed of the smaller body before collision is \_\_\_\_\_ **Marks:[4.00]**

**Q.No.29:** A series LCR circuit is connected to an AC source of 220 V, 50 Hz. The circuit contains a resistance  $R = 80 \Omega$ , an inductor of inductive reactance  $X_L = 70 \Omega$ , and a capacitor of capacitive reactance  $X_C = 130 \Omega$ . The power factor of circuit is  $\frac{x}{10}$ . The value of x is: **Marks:[4.00]**

**Q.No.30:** A spherical drop of liquid splits into 1000 identical spherical drops. If  $u_i$  is the surface energy of the original drop and  $u_f$  is the total surface energy of the resulting drops, the (ignoring evaporation),  $\frac{u_f}{u_i} = \left(\frac{10}{x}\right)$ . Then value of x is \_\_\_\_\_: **Marks:[4.00]**

**Chemistry**

**Q.No.31:** Which of the following represents the correct order of metallic character of the given elements?

- A. Be < Si < K < Mg
- B. K < Mg < Be < Si
- C. Be < Si < Mg < K
- D. Si < Be < Mg < K

**Marks:[4.00]**

**Q.No.32:** Match List I with List II

| List - I<br>(Amines) |                           | List - II<br>(pK <sub>b</sub> ) |      |
|----------------------|---------------------------|---------------------------------|------|
| A.                   | Aniline                   | I.                              | 3.25 |
| B.                   | Ethanamine                | II.                             | 3.00 |
| C.                   | N-Ethylethanamine         | III.                            | 9.38 |
| D.                   | N,<br>N-Diethylethanamine | IV.                             | 3.29 |

Choose the correct answer from the options given below:

- A. A-III, B-II, C-I, D-IV
- B. A-III, B-II, C-IV, D-I
- C. A-I, B-IV, C-II, D-III
- D. A-III, B-IV, C-II, D-I

**Marks:[4.00]**

**Q.No.33:** Given below are two statements, one is labelled as **Assertion A** and the other is labelled as **Reason R**.

**Assertion A:** Carbon forms two important oxides – CO and CO<sub>2</sub>. CO is neutral whereas CO<sub>2</sub> is acidic in nature.

**Reason:** CO<sub>2</sub> can combine with water in a limited way to form carbonic acid, while CO is sparingly soluble in water.

In the light of the above statements, choose the most appropriate answer from the options given below.

- A. Both A and R are correct and R is the correct explanation of A
- B. A is not correct but R is correct
- C. A is correct but R is not correct
- D. Both A and R are correct but R is NOT the correct explanation of A

**Marks:[4.00]**

**Q.No.34: Statement I:** Dipole moment is a vector quantity and by convention it is depicted by a small arrow with tail on the negative centre and head pointing towards the positive centre.

**Statement II:** The crossed arrow of the dipole moment symbolized the direction of the shift of charges in the molecules.

In the light of the above statements, choose the most appropriate answer from the options given below.

- A. Statement I is incorrect but Statement II is correct
- B. Both Statement I and Statement II are incorrect
- C. Both Statement I and Statement II are correct
- D. Statement I is correct but Statement II is incorrect

**Marks:[4.00]**

**Q.No.35:** Which one among the following metals is the weakest reducing agent?

- A. Li
- B. Rb
- C. Na
- D. K

**Marks:[4.00]**

**Q.No.36:** Find out the major product from the following reaction.

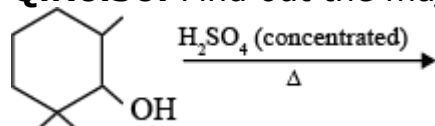

- A.
- B.
- C.
- D.

**Marks:[4.00]**

**Q.No.37:** A. Ammonium salts produce haze in atmosphere.  
 B. Ozone gets produced when atmospheric oxygen reacts with chlorine radicals.  
 C. Polychlorinated biphenyls act as cleansing solvents.  
 D. 'Blue baby' syndrome occurs due to the presence of excess of sulphate ions in water.

Choose the correct answer from the options given below.

- A. A and C only
- B. A, B and C only

C. A and D only

D. B and C only

Marks:[4.00]

**Q.No.38:** A chloride salt solution acidified with dil.HNO<sub>3</sub> gives a curdy white precipitate, [A], on addition of AgNO<sub>3</sub>. [A] on treatment with NH<sub>4</sub>OH gives a clear solution, B. A and B are respectively

A. AgCl & (NH<sub>4</sub>)[Ag(OH)<sub>2</sub>]

B. H[AgCl<sub>3</sub>] & [Ag(NH<sub>3</sub>)<sub>2</sub>]Cl

C. AgCl & [Ag(NH<sub>3</sub>)<sub>2</sub>]Cl

D. H[AgCl<sub>3</sub>] & (NH<sub>4</sub>)[Ag(OH)<sub>2</sub>]

Marks:[4.00]

**Q.No.39:** Match List - I with List - II

| List - I<br>(Name of polymer) |          | List - II<br>(Uses) |                     |
|-------------------------------|----------|---------------------|---------------------|
| A.                            | Glyptal  | I.                  | Flexible pipes      |
| B.                            | Neoprene | II.                 | Synthetic wool      |
| C.                            | Acrylan  | III.                | Paints and Lacquers |
| D.                            | LDP      | IV.                 | Gaskets             |

Choose the correct answer from the options given below:

A. A-III, B-I, C-IV, D-II

B. A-III, B-IV, C-II, D-I

C. A-III, B-IV, C-I, D-II

D. A-III, B-II, C-IV, D-I

Marks:[4.00]

**Q.No.40:** Match List - I with List - II

| List - I<br>(Isomeric pairs) |                                    | List - II<br>(Type of isomers) |                    |
|------------------------------|------------------------------------|--------------------------------|--------------------|
| A.                           | Propanamine and N-Methylethanamine | I.                             | Metamers           |
| B.                           | Hexan-2-one and Hexan-3-one        | II.                            | Positional isomers |
| C.                           | Ethanamide and Hydroxyethanimine   | III.                           | Functional isomers |
| D.                           | o-nitrophenol and p-nitrophenol    | IV.                            | Tautomers          |

Choose the correct answer from the options given below.

A. A-III, B-I, C-IV, D-II

B. A-IV, B-III, C-I, D-II

C. A-II, B-III, C-I, D-IV

D. A-III, B-IV, C-I, D-II

**Marks:[4.00]**

**Q.No.41:** Potassium dichromate acts as a strong oxidizing agent in acidic solution. During this process, the oxidation state changes from

A. +2 to +1

B. +6 to +2

C. +3 to +1

D. +6 to +3

**Marks:[4.00]**

**Q.No.42:** Given below are two statements, one is labelled as **Assertion A** and the other is labelled as **Reason R**

**Assertion A:** Butylated hydroxy anisole when added to butter increases its shelf life.

**Reason R:** Butylated hydroxy anisole is more reactive towards oxygen than food.

In the light of the above statements, choose the most appropriate answer from the options given below.

A. Both A and R are correct but R is NOT the correct explanation of A

B. A is not correct but R is correct

C. Both A and R are correct and R is the correct explanation of A

D. A is correct but R is not correct

**Marks:[4.00]**

**Q.No.43:** When the hydrogen ion concentration  $[H^+]$  changes by a factor of 1000, the value of pH of the solution \_\_\_\_\_

A. increases by 1000 units

B. decreases by 2 units

C. increases by 2 units

D. decreases by 3 units

**Marks:[4.00]**

**Q.No.44:** The isomeric deuterated bromide with molecular formula  $C_4H_8DBr$  having two chiral carbon atoms is

- A. 2-Bromo-2-deuterobutane
- B. 2-Bromo-1-deutero-2-methylpropane
- C. 2-Bromo-3-deuterobutane
- D. 2-Bromo-1-deuterobutane

**Marks:[4.00]**

**Q.No.45:** Match List - I with List - II

| List - I<br>(Coordination entity) |                       | List - II<br>(Wavelength of light absorbed in nm) |     |
|-----------------------------------|-----------------------|---|-----|
| A.                                | $[CoCl(NH_3)_5]^{2+}$ | I.  | 310 |
| B.                                | $[Co(NH_3)_6]^{3+}$   | II.   | 475 |
| C.                                | $[Co(CN)_6]^{3-}$     | III.  | 535 |
| D.                                | $[Cu(H_2O)_4]^{2+}$   | IV.   | 600 |

Choose the correct answer from the options given below:

- A. A-III, B-I, C-II, D-IV
- B. A-IV, B-I, C-III, D-II
- C. A-II, B-III, C-IV, D-I
- D. A-III, B-II, C-I, D-IV

**Marks:[4.00]**

**Q.No.46:** 'A' in the given reaction is

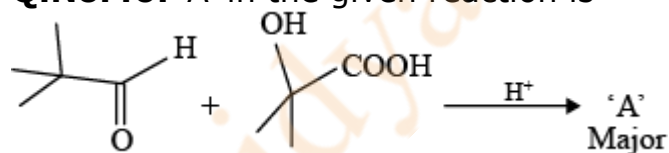

- A.
- B.
- C.

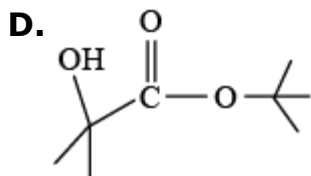

Marks:[4.00]

**Q.No.47:** Given below are two statements, one is labelled as **Assertion A** and the other is labelled as **Reason R**

**Assertion A:** The alkali metals and their salts impart characteristic colour to reducing flame.

**Reason R:** Alkali metals can be detected using flame tests.

In the light of the above statements, choose the most appropriate answer from the options given below.

- A. Both A and R are correct and R is the correct explanation of A
- B. Both A and R are correct but R is NOT the correct explanation of A
- C. A is not correct but R is correct
- D. A is correct but R is not correct

Marks:[4.00]

**Q.No.48:** Match List - I with List - II

| List - I |                 | List - II |  |
|----------|-----------------|-----------|--|
| A.       | Cobalt catalyst | I.        | (H <sub>2</sub> + Cl <sub>2</sub> ) production |
| B.       | Syngas          | II.       | Water gas production                           |
| C.       | Nickel catalyst | III.      | Coal gasification                              |
| D.       | Brine solution  | IV.       | Methanol production                            |

Choose the correct answer from the options given below:

- A. A-IV, B-I, C-II, D-III
- B. A-IV, B-III, C-I, D-II
- C. A-II, B-III, C-IV, D-I
- D. A-IV, B-III, C-II, D-I

Marks:[4.00]

**Q.No.49:** Given below are two statements:

**Statement I:** In froth floatation method a rotating paddle agitates the mixture to drive air out of it.

**Statement II:** Iron pyrites are generally avoided for extraction of iron due to environmental reasons.

In the light of the above statements, choose the correct answer from the options given below:

- A. Statement I is false but Statement II is true

- B. Statement I is true but Statement II is false
- C. Both Statement I and Statement II are false
- D. Both Statement I and Statement II are true

**Marks:[4.00]**

**Q.No.50:** What is the mass ratio of ethylene glycol ( $C_2H_6O_2$ , molar mass = 62 g/mol) required for making 500 g of 0.25 molal aqueous solution and 250 mL of 0.25 molal aqueous solution?

- A. 2 : 1
- B. 1 : 2
- C. 1 : 1
- D. 3 : 1

**Marks:[4.00]**

**Q.No.51:** A first order reaction has the rate constant,  $k = 4.6 \times 10^{-3} \text{ s}^{-1}$ . The number of correct statement/s from the following is/are \_\_\_\_\_ Given:  $\log 3 = 0.48$

- A. Reaction completes in 1000 s.
- B. The reaction has a half-life of 500 s.
- C. The time required for 10% completion is 25 times the time required for 90% completion.
- D. The degree of dissociation is equal to  $(1 - e^{-kt})$
- E. The rate and the rate constant have the same unit.

**Marks:[4.00]**

**Q.No.52:** The number of incorrect statement/s from the following is/are \_\_\_\_\_

- A. Water vapours are adsorbed by anhydrous calcium chloride.
- B. There is a decrease in surface energy during adsorption.
- C. As the adsorption proceeds,  $\Delta H$  becomes more and more negative.
- D. Adsorption is accompanied by decrease in entropy of the system.

**Marks:[4.00]**

**Q.No.53:** Number of hydrogen atoms per molecule of a hydrocarbon A having 85.8% carbon is \_\_\_\_\_

(Given: Molar mass of A =  $84 \text{ g mol}^{-1}$ )

**Marks:[4.00]**



**Q.No.54:** The number of given orbitals which have electron density along the axis is \_\_\_\_\_

$p_x, p_y, p_z, d_{xy}, d_{yz}, d_{xz}, d_{z^2}, d_{x^2 - y^2}$

**Marks:[4.00]**

**Q.No.55:** Number of compounds giving (i) red colouration with ceric ammonium nitrate and also (ii) positive iodoform test from the following is \_\_\_\_\_

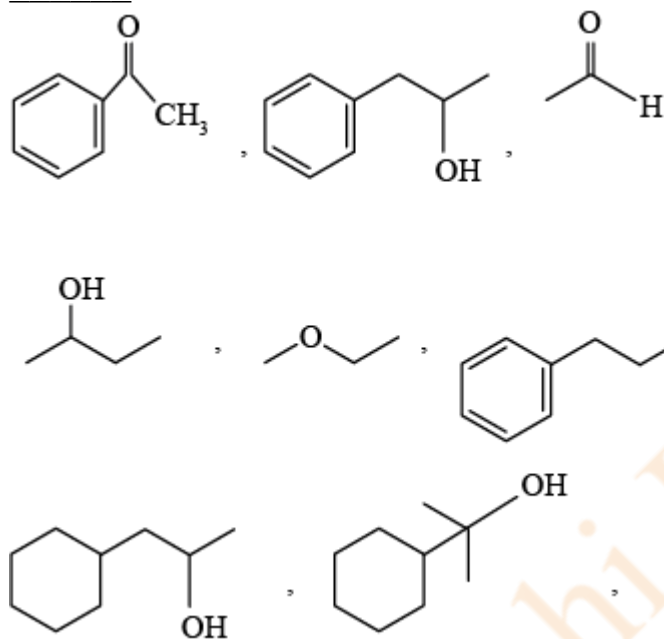

**Marks:[4.00]**

**Q.No.56:** The number of pairs of the solutions having the same value of the osmotic pressure from the following is \_\_\_\_\_.

(Assume 100% ionization)

- (A) 0.500 M  $C_2H_5OH(aq)$  and 0.25 M  $KBr(aq)$
- (B) 0.100 M  $K_4[Fe(CN)_6]$  (aq) and 0.100 M  $FeSO_4(NH_4)_2SO_4(aq)$
- (C) 0.05 M  $K_4[Fe(CN)_6]$  (aq) and 0.25 M  $NaCl$  (aq)
- (D) 0.15 M  $NaCl$  (aq) and 0.1 M  $BaCl_2$  (aq)
- (E) 0.02 M  $KCl.MgCl_2.6H_2O$  (aq) and 0.05 M  $KCl$  (aq)

**Marks:[4.00]**

**Q.No.57:** 28.0 L of  $CO_2$  is produced on complete combustion of 16.8 L gaseous mixture of ethene and methane at  $25^\circ C$  and 1 atm. Heat evolved during the combustion process is \_\_\_\_\_ kJ.

Given:  $\Delta H_C(CH_4) = -900 \text{ kJ mol}^{-1}$

$\Delta H_C(C_2H_4) = -1400 \text{ kJ mol}^{-1}$

**Marks:[4.00]**

**Q.No.58:** Pt(s)|H<sub>2</sub>(g)(1bar)|H<sup>+</sup>(aq)(1M)||M<sup>3+</sup>(aq), M<sup>+</sup>(aq)|Pt(s)

The E<sub>cell</sub> for the given cell is 0.1115 V at 298 K when  $\frac{[M^+(aq)]}{[M^{3+}(aq)]} = 10^a$

The value of a is \_\_\_\_\_

Given :  $E_{M^{3+}/M^+}^\theta = 0.2 \text{ V}$

$$\frac{2.303 RT}{F} = 0.059 \text{ V}$$

**Marks:[4.00]**

**Q.No.59:** Total number of moles of AgCl precipitated on addition of excess of AgNO<sub>3</sub> to one mole each of the following complexes [Co(NH<sub>3</sub>)<sub>4</sub>Cl<sub>2</sub>]Cl, [Ni(H<sub>2</sub>O)<sub>6</sub>]Cl<sub>2</sub>, [Pt(NH<sub>3</sub>)<sub>2</sub>Cl<sub>2</sub>] and [Pd(NH<sub>3</sub>)<sub>4</sub>]Cl<sub>2</sub> is \_\_\_\_\_

**Marks:[4.00]**

**Q.No.60:** Based on the given figure, the number of correct statement/s is/are

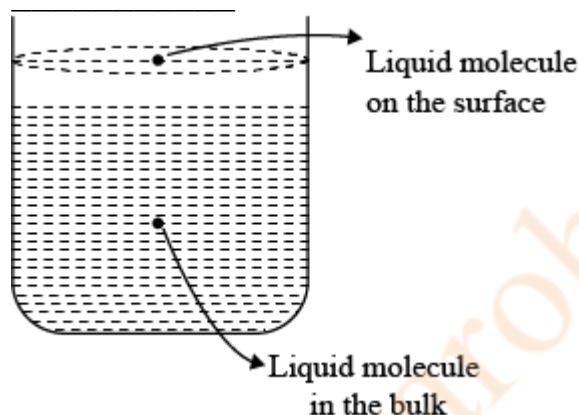

- A. Surface tension is the outcome of equal attractive and repulsive forces acting on the liquid molecule in bulk.
- B. Surface tension is due to uneven force acting on the molecules present on the surface.
- C. The molecule in the bulk can never come to the liquid surface.
- D. The molecules on the surface are responsible for vapour pressure if the system is a closed system.

**Marks:[4.00]**

**Mathematics**

**Q.No.61:** Let  $A = \begin{bmatrix} \frac{1}{\sqrt{10}} & \frac{3}{\sqrt{10}} \\ \frac{-3}{\sqrt{10}} & \frac{1}{\sqrt{10}} \end{bmatrix}$  and  $B = \begin{bmatrix} 1 & -i \\ 0 & 1 \end{bmatrix}$ , where  $i = \sqrt{-1}$ .

If  $M = A^T B A$ , then the inverse of the matrix  $A M^{2023} A^T$  is

**A.**  $\begin{bmatrix} 1 & 0 \\ -2023i & 1 \end{bmatrix}$

**B.**  $\begin{bmatrix} 1 & -2023i \\ 0 & 1 \end{bmatrix}$

**C.**  $\begin{bmatrix} 1 & 2023i \\ 0 & 1 \end{bmatrix}$

**D.**  $\begin{bmatrix} 1 & 0 \\ 2023i & 1 \end{bmatrix}$

**Marks:[4.00]**

**Q.No.62:** Let  $\vec{a} = -\hat{i} - \hat{j} + \hat{k}$ ,  $\vec{a} \cdot \vec{b} = 1$  and  $\vec{a} \times \vec{b} = \vec{i} - \vec{j}$ . Then  $\vec{a} - 6\vec{b}$  is equal to

**A.**  $3(\hat{i} + \hat{j} - \hat{k})$

**B.**  $3(\hat{i} - \hat{j} - \hat{k})$

**C.**  $3(\hat{i} - \hat{j} + \hat{k})$

**D.**  $3(\hat{i} + \hat{j} + \hat{k})$

**Marks:[4.00]**

**Q.No.63:** Let  $\Delta, \nabla \in \{\wedge, \vee\}$  be such that  $(p \rightarrow q) \Delta (p \nabla q)$  is a tautology. Then

**A.**  $\Delta = \vee, \nabla = \vee$

**B.**  $\Delta = \vee, \nabla = \wedge$

**C.**  $\Delta = \wedge, \nabla = \vee$

**D.**  $\Delta = \wedge, \nabla = \wedge$

**Marks:[4.00]**

**Q.No.64:** The equations of two sides of a variable triangle are  $x = 0$  and  $y = 3$ , and its third side is a tangent to the parabola  $y^2 = 6x$ . The locus of its circumcentre is

**A.**  $4y^2 + 18y + 3x + 18 = 0$

**B.**  $4y^2 - 18y - 3x - 18 = 0$

**C.**  $4y^2 - 18y + 3x + 18 = 0$

**D.**  $4y^2 - 18y - 3x + 18 = 0$

**Marks:[4.00]**

**Q.No.65:** The shortest distance between the lines  $x + 1 = 2y = -12z$  and  $x = y + 2 = 6z - 6$  is

- A. 2
- B.  $\frac{3}{2}$
- C. 3
- D.  $\frac{5}{2}$

**Marks:[4.00]**

**Q.No.66:** If the function  $f(x) = \begin{cases} (1 + |\cos x|) \frac{\lambda}{|\cos x|}, & 0 < x < \frac{\pi}{2} \\ \mu, & x = \frac{\pi}{2} \\ \frac{\cot 6x}{e^{\cot 4x}}, & \frac{\pi}{2} < x < \pi \end{cases}$  is

continuous at  $x = \frac{\pi}{2}$ , then  $9\lambda + 6 \log_e \mu + \mu^6 - e^{6\lambda}$  is equal to

- A. 11
- B. 8
- C. 10
- D.  $2e^4 + 8$

**Marks:[4.00]**

**Q.No.67:** If the four points, whose position vectors are  $3\hat{i} - 4\hat{j} + 2\hat{k}$ ,  $\hat{i} + 2\hat{j} - \hat{k}$ ,  $-2\hat{i} - \hat{j} + 3\hat{k}$  and  $5\hat{i} - 2\alpha\hat{j} + 4\hat{k}$  are coplanar, then  $\alpha$  is equal to

- A.  $\frac{107}{17}$
- B.  $-\frac{107}{17}$
- C.  $\frac{73}{17}$
- D.  $-\frac{73}{17}$

**Marks:[4.00]**

**Q.No.68:** Let T and C respectively be the transverse and conjugate axes of the hyperbola  $16x^2 - y^2 + 64x + 4y + 44 = 0$ . Then the area of the region above the parabola  $x^2 = y + 4$ , below the transverse axis T and on the right of the conjugate axis C is:

- A.  $4\sqrt{6} + \frac{28}{3}$
- B.  $4\sqrt{6} - \frac{44}{3}$
- C.  $4\sqrt{6} + \frac{44}{3}$

D.  $4\sqrt{6} - \frac{28}{3}$

Marks:[4.00]

**Q.No.69:** The number of numbers, strictly between 5000 and 10000 can be formed using the digits 1, 3, 5, 7, 9 without repetition, is

- A. 6
- B. 12
- C. 72
- D. 120

Marks:[4.00]

**Q.No.70:** Let  $y = y(t)$  be a solution of the differential equation  $\frac{dy}{dt} + \alpha y = \gamma e^{-\beta t}$  where,  $\alpha > 0$ ,  $\beta > 0$  and  $\gamma > 0$ . Then  $\lim_{x \rightarrow \infty} y(t)$

- A. Does not exist
- B. Is 0
- C. Is -1
- D. Is 1

Marks:[4.00]

**Q.No.71:**  $\sum_{k=0}^6 {}^{51-k}C_3$  is equal to

- A.  ${}^{52}C_3 - {}^{45}C_3$
- B.  ${}^{52}C_4 - {}^{45}C_4$
- C.  ${}^{51}C_3 - {}^{45}C_3$
- D.  ${}^{51}C_4 - {}^{45}C_4$

Marks:[4.00]

**Q.No.72:** Let A, B, C be  $3 \times 3$  matrices such that A is symmetric and B and C are skew-symmetric.

Consider the statements

(S<sub>1</sub>)  $A^{13}B^{26} - B^{26}A^{13}$  is symmetric

(S<sub>2</sub>)  $A^{26}C^{13} - C^{13}A^{26}$  is symmetric

Then,

- A. Both S<sub>1</sub> and S<sub>2</sub> are true
- B. Only S<sub>2</sub> is true
- C. Only S<sub>1</sub> is true
- D. Both S<sub>1</sub> and S<sub>2</sub> are false

Marks:[4.00]

**Q.No.73:** Let  $f(x) = 2x^n + \lambda$ ,  $\lambda \in \mathbb{R}$ ,  $n \in \mathbb{N}$  and  $f(4) = 133$ ,  $f(5) = 255$ . Then the sum of all the positive integer divisors of  $(f(3) - f(2))$  is

- A. 61
- B. 59
- C. 60
- D. 58

**Marks:[4.00]**

**Q.No.74:** The number of functions  $f : \{1, 2, 3, 4\} \longrightarrow \{a \in \mathbb{Z} \mid |a| \leq 8\}$  satisfying  $f(n) + \frac{1}{n}f(n+1) = 1, \forall n \in \{1, 2, 3\}$  is

- A. 3
- B. 2
- C. 4
- D. 1

**Marks:[4.00]**

**Q.No.75:** Let the function  $f(x) = 2x^3 + (2p - 7)x^2 + 3(2p - 9)x - 6$  have a maxima for some value of  $x < 0$  and a minima for some value of  $x > 0$ . Then, the set of all values of  $p$  is

- A.  $\left(0, \frac{9}{2}\right)$
- B.  $\left(\frac{9}{2}, \infty\right)$
- C.  $\left(-\frac{9}{2}, \frac{9}{2}\right)$
- D.  $\left(-\infty, \frac{9}{2}\right)$

**Marks:[4.00]**

**Q.No.76:** The integral  $16 \int_1^2 \frac{dx}{x^3(x^2+2)}$  is equal to

- A.  $\frac{11}{12} + \log_e 4$
- B.  $\frac{11}{6} - \log_e 4$
- C.  $\frac{11}{12} - \log_e 4$
- D.  $\frac{11}{6} + \log_e 4$

**Marks:[4.00]**

**Q.No.77:** Let  $f : R \rightarrow R$  be a function defined by  $f(x) = \log_{\sqrt{m}} \left\{ \sqrt{2} (\sin x - \cos x) + m - 2 \right\}$ , for some  $m$ , such that the range of  $f$  is  $[0, 2]$ . Then the value of  $m$  is \_\_\_\_\_

- A. 4
- B. 2
- C. 3
- D. 5

**Marks:[4.00]**

**Q.No.78:** Let  $N$  be the sum of the numbers appeared when two fair dice are rolled and let the probability that  $N - 2, \sqrt{3N}, N + 2$  are in geometric progression be  $\frac{k}{48}$ . Then the value of  $k$  is

- A. 16
- B. 8
- C. 4
- D. 2

**Marks:[4.00]**

**Q.No.79:** Let  $z$  be a complex number such that  $\left| \frac{z-2i}{z+i} \right| = 2, z \neq -i$ . Then  $z$  lies on the circle of radius 2 and centre

- A.  $(0, 2)$
- B.  $(2, 0)$
- C.  $(0, 0)$
- D.  $(0, -2)$

**Marks:[4.00]**

**Q.No.80:** The foot of perpendicular of the point  $(2, 0, 5)$  on the line  $\frac{x+1}{2} = \frac{y-1}{5} = \frac{z+1}{-1}$  is  $(\alpha, \beta, \gamma)$ . Then, which of the following is NOT correct?

A.  $\frac{\alpha\beta}{\gamma} = \frac{4}{15}$

B.  $\frac{\beta}{\gamma} = -5$

C.  $\frac{\gamma}{\alpha} = \frac{5}{8}$

D.  $\frac{\alpha}{\beta} = -8$

**Marks:[4.00]**

**Q.No.81:** Let  $a \in \mathbb{R}$  and let  $\alpha, \beta$  be the roots of the equation  $x^2 + 60^{\frac{1}{4}}x + a = 0$ . If  $\alpha^4 + \beta^4 = -30$ , then the product of all possible values of  $a$  is \_\_\_\_\_

**Marks:[4.00]**

**Q.No.82:** For the two positive number  $a, b$ , if  $a, b$  and  $\frac{1}{18}$  are in a geometric progression, while  $\frac{1}{a}, 10$  and  $\frac{1}{b}$  are in arithmetic progression, then  $16a + 12b$  is equal to \_\_\_\_\_.

**Marks:[4.00]**

**Q.No.83:** Points  $P(-3, 2)$ ,  $Q(9, 10)$  and  $R(a, 4)$  lie on a circle  $C$  with  $PR$  as its diameter. The tangents to  $C$  at the points  $Q$  and  $R$  intersect at the point  $S$ . If  $S$  lies on the line  $2x - ky = 1$ , then  $k$  is equal to \_\_\_\_\_

**Marks:[4.00]**

**Q.No.84:** If the shortest distance between the line joining the points  $(1, 2, 3)$  and  $(2, 3, 4)$ , and the line  $\frac{x-1}{2} = \frac{y+1}{-1} = \frac{z-2}{0}$  is  $a$ , then  $28a^2$  is equal to \_\_\_\_\_.

**Marks:[4.00]**

**Q.No.85:** Suppose Anil's mother wants to give 5 whole fruits to Anil from a basket of 7 red apples, 5 white apples and 8 oranges. If in the selected 5 fruits, at least 2 oranges, at least one red apple and at least one white apple must be given, then the number of ways, Anil's mother can offer 5 fruits to Anil is \_\_\_\_\_

**Marks:[4.00]**



**Q.No.86:** 25% of the population are smokers. A smoker has 27 times more chances to develop lung cancer than a non-smoker. A person is diagnosed with lung cancer and the probability that this person is a smoker is  $\frac{k}{10}$ . Then the value of  $k$  is \_\_\_\_\_.

**Marks:[4.00]**

**Q.No.87:** A triangle is formed by X-axis and the line  $3x + 4y = 60$ . Then the number of points  $P(a, b)$ , which lie strictly inside the triangle, where  $a$  is integer and  $b$  is a multiple of  $a$ , is \_\_\_\_\_.

**Marks:[4.00]**

**Q.No.88:** The remainder when  $(2023)^{2023}$  is divided by 35 is \_\_\_\_\_.

**Marks:[4.00]**

**Q.No.89:** If  $m$  and  $n$  respectively are the numbers of positive and negative values of  $\theta$  in the interval  $[-\pi, \pi]$  that satisfy the equation  $\cos 2\theta \cos \frac{\theta}{2} = \cos 3\theta \cos \frac{9\theta}{2}$ , then  $mn$  is equal to \_\_\_\_\_.

**Marks:[4.00]**

**Q.No.90:** If  $\int_{\frac{1}{3}}^3 |\log_e x| dx = \frac{m}{n} \log_e \left( \frac{n^2}{e} \right)$ , where  $m$  and  $n$  are coprime natural numbers, then  $m^2 + n^2 - 5$  is equal to \_\_\_\_\_.

**Marks:[4.00]**